

706C Microwave LED Sensor Lamp

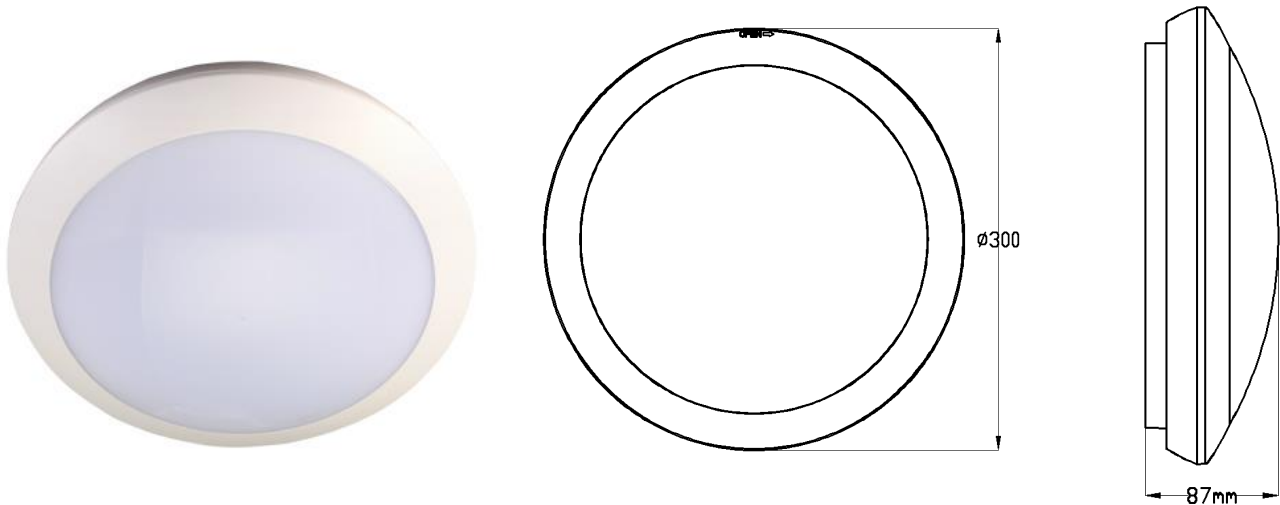

Instruction

Welcome to use 706C Microwave LED Sensor Lamp!

The product adopts microwave LED sensor mould with high-frequency electro-magnetic wave (5.8GHz) and integrated circuit, SMD LED. It gathers automatism, convenience, safety, saving-energy and practical functions. The wide detection field is consisting of detectors. It works by receiving human motion. When one enters the detection field, it can start the load at once and identify automatically day and night. Its installation is very convenient and its application is very wide. Detection is possible to go through doors, panes of glass or thin walls.

SPECIFICATION:

Power Source: 220 -240V/AC

Detection angle: 180°/360°

Daylight Sensor: 5lux, 15lux, 50lux,
2000lux (choice)

Transmission Power: <0.2mW

Hold Time: 10s, 90s, 3min,
10min (choice)

Power Consumption: approx 0.9W

Stand-by Period: 0s, 30s, 10min,
+∞ (choice)

Power Frequency: 50/60Hz

Detection Range: 50%, 100% (choice)

Detection Distance: wall: 5-15m (adjustable)
ceiling: 2-8m (radius), adjustable

HF System: 5.8GHz CW radar, ISM band

Installing Height: wall: 1.5-3.5m
ceiling: 2-4m

Detection Motion Speed: 0.6-1.5m/s

Stand-by dimming Level: 10%, 20% (choice)

Rated Load: 16W(1300LM)

FUNCTION:

- Can identify day and night: It can work in the daytime and at night when two knobs are on above position (Daylight Sensor). It can work in the ambient light less than 5LUX when two knobs are on below position (Daylight Sensor). As for the adjustment pattern, please refer to the testing pattern.
- Hold time is optional. It can be set according to the consumer's desire. The minimum time is 10sec. The maximum is 10min.

- It offers 3 levels of light: 100 %--> dimmed light (10% or 20% optional) -->off; and 2 periods of selectable waiting time, motion hold time and stand-by period; selectable LUX value and choice of detection area.

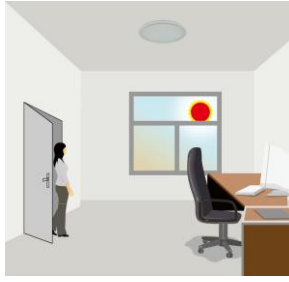

With ambient light more than daylight threshold, the lamp does not switch on when someone enters the room

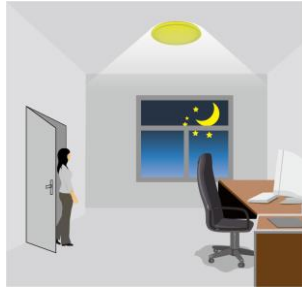

With ambient light less than daylight threshold, the lamp will be on 100% when someone enters the room

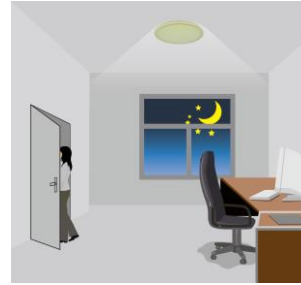

People left, light dims to 10% or 20% (optional) stand-by level after hold time

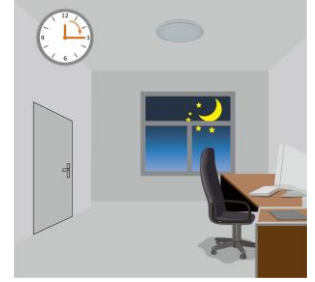

Light switches off automatically after the stand-by period elapsed

SENSOR INFORMATION:

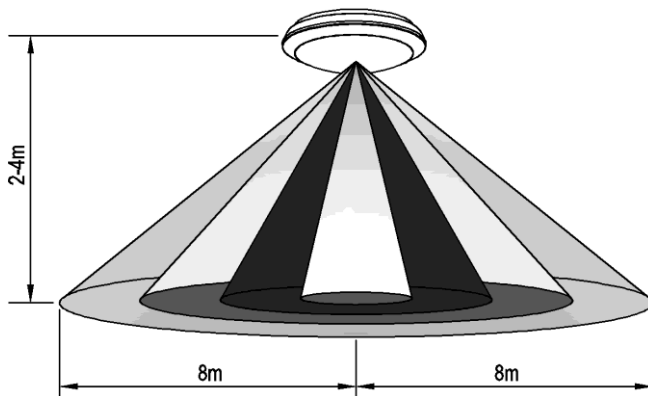

Height of installation: 2-4m

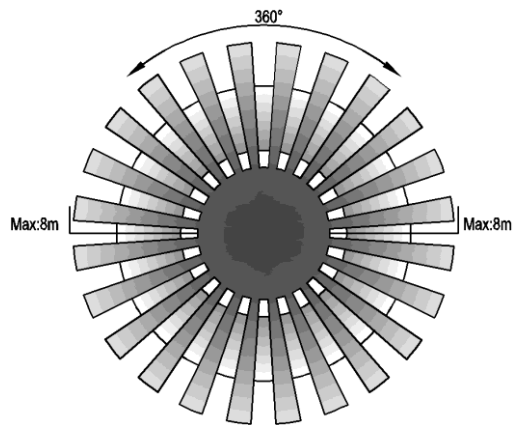

Detection Area: Max. 8m (radius)

INSTALLATION: (see the diagram)

- Switch off the power.
- Unload the plastic clockwise to open it, screw off the screws on the lampshade and open the lampshade
- Put the wire through the wire holes with rubber band which is at the bottom pan of lamp, and connect the wire with terminal according to connect-wire diagram.
- Fix the metal bracket base on the ceiling through the holes on the bottom pan with enclosed inflated screws
- Switch on the power and test it.

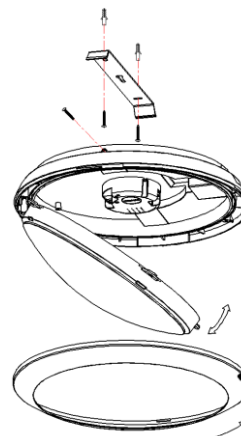
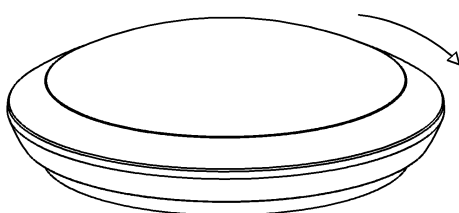

SETTING:

Detection Range

Detection distance can be set with different combinations of DIP switches to precisely fit for each specific application



1	
●	100%
○	50%

Hold Time

Hold Time means the time period you would like to keep the lamp on 100% after the person has left the detection distance



2	3	
●	●	10S
○	●	90S
●	○	3min
○	○	10min

Daylight sensor

The LUX value can be set on DIP switches in order to fit different ambient light.



4	5	
●	●	2000Lux
○	●	50Lux
●	○	15Lux
○	○	5Lux

Stand-by Period

This time period you would like to keep at the low light output level before it is completely switched off in the long absence person

Note: "+∞" means fixture keeps on stand-by dimming level and never switches off.
 "0s" means no dimming function



6	7	
●	●	0S
○	●	30S
●	○	10min
○	○	+∞

Stand-by Dimming level

This is dimmed low light control light output level you would like to have after the hold time in the absence person



8	
●	10%
○	20%

CONNECTION-WIRE DIAGRAM

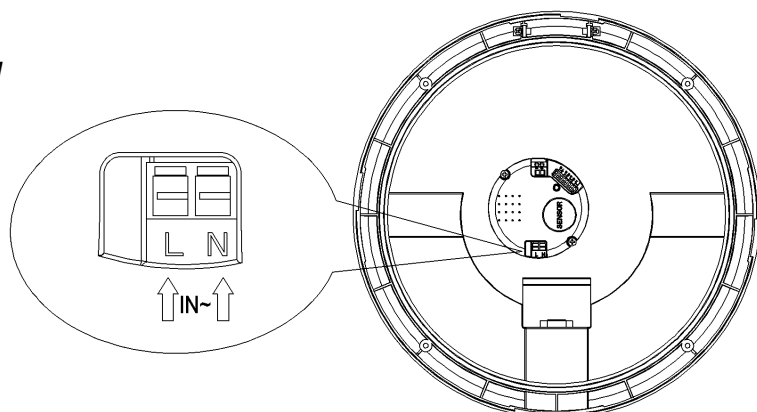

TEST:

- Slide the all knobs on “above” position. When you switch on the power, the light will be on at once, and 10 sec later without induction signal the light will turn off slowly. Then if the sensor receives induction signal, it can work normally

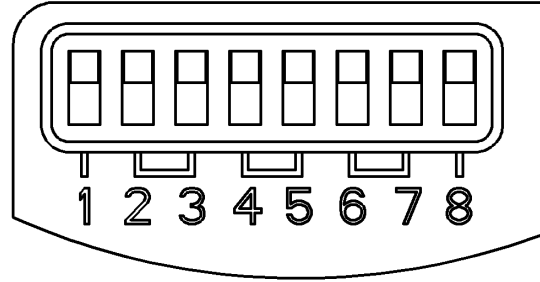

- Adjust the stand-by period to “30s”, when the sensor receives induction signal, the light will be 100% on; 10sec later, the light dims slowly to 10% or 20% on for 30sec and then turn off. If



Detection Range		Hold Time		Daylight Sensor		STBY		STBY%	
1		2	3	4	5	6	7	8	
●	100%	●	●	●	●	●	●	●	10%
○	50%	○	●	○	●	○	●	○	20%
		●	○	●	○	●	○		
		○	○	○	○	○	○		

the sensor receives second induction signal within the stand-by period, the light will be 100% on.

Note: when testing in daylight, please turn LUX knob to ☀ (SUN) position, otherwise the sensor light could not work!

NOTES:

- Electrician or experienced human can install it.
- Can not be installed on the uneven and shaky surface
- In front of the sensor there shouldn't be obstructive object affecting detection.
- Avoid installing it near the metal and glass which may affect the sensor.
- For your safety, please don't open the case if you find hitch after installation.

SOME PROBLEM AND SOLVED WAY:

- The load doesn't work:
 - a. Check the power and the load.
 - b. Whether the indicator light is turned on after sensing? If yes, please check load.
 - c. If the indicator light is not on after sensing, please check if the working light corresponds to the ambient light.
 - d. Please check if the working voltage corresponds to the power source.
- The sensitivity is poor:
 - a. Please check if in front of the sensor there shouldn't be obstructive object that affect to receive the signals.
 - b. Please check if the signal source is in the detection fields.
 - c. Please check the installation height.
- The sensor can't shut automatically the load:
 - a. If there are continual signals in the detection fields.
 - b. If the time delay is set to the longest.
 - c. If the power corresponds to the instruction.