

# 0/1-10V WiFi + RF + Push Dimmer

L2(WT) 0/1-10V WiFi + RF + Push Dimmer

Model No.: L2(WT)

2 channel 0/1-10V signal output/AC relay output/Tuya APP cloud control/Voice control/RF dimming/Push Dim



## Features

- WiFi + RF + AC push 0/1-10V dimmer, output 2 channel 0/1-10V signal.
- High voltage AC input, High voltage AC relay output.
- Dimming or dual color control selectable by DIP switch.
- For dual color control, the two channel output can be set as warm white and cool white respectively, or one for brightness adjust and the other for color temperature adjust.
- 0-10V or 1-10V output selectable by DIP switch.
- Tuya APP cloud control, support on/off, color temperature and brightness adjust, delay turn on/off light, timer run, scene edit and music play function.
- Voice control, support amazon ECHO and TmallGenie smart speaker.
- 256 levels 0-100% dimming smoothly without any flash.
- Compatibility with RF 2.4G single zone or multiple zone remote control.
- Each L2(WT) controller can also work as WiFi:RF converter, then use Tuya APP to control one or more RF dimming LED controller or driver synchronously.
- Connect with external push switch to achieve on/off and 0-100% dimming function.
- Light on/off fade time 3s selectable.

CE RoHS LVD

## Technical Parameters

Input and Output	
Input voltage	AC100-240V
Output signal	2 x 0/1-10V
Output current	0/1-10V: 20mA/CH AC: Max 3A

Safety and EMC	
EMC standard (EMC)	ETSI EN 301 489-1 V2.2.3 ETSI EN 301 489-17 V3.2.4
Safety standard(LVD)	EN 62368-1:2020+A1 1:2020
Radio Equipment(RED)	ETSI EN 300 328 V2.2.2
Certification	CE,EMC,LVD,RED

Dimming data	
Input signal	Tuya APP + RF + Push Dim
RF Control distance	30m(Barrier-free space)
Dimming level	256 levels
Dimming range	0-100%

Environment	
Operation temperature	Ta: -30°C ~ +55°C
Case temperature (Max.)	Tc: +65°C
IP rating	IP20

Warranty	
Warranty	5 years

## Mechanical Structures and Installations

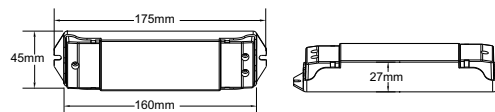
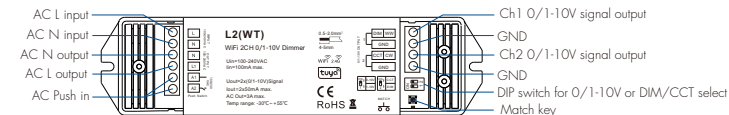

## System wiring

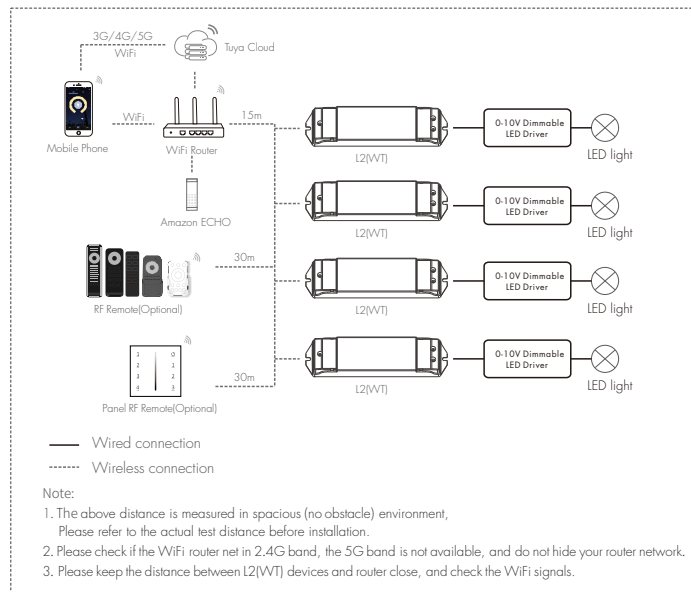

## Wiring diagram

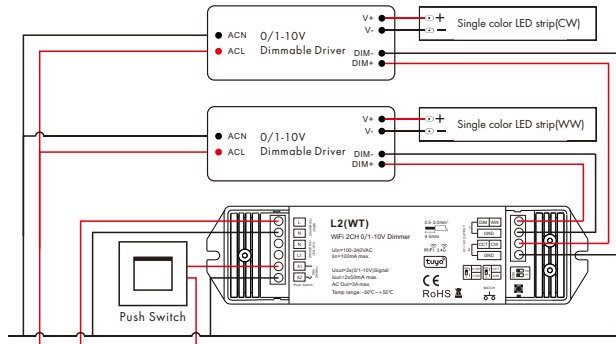

- Note:**
1. We recommend the number of LED drivers connected to 0/1-10V dimmer does not exceed 100 pieces. The maximum length of the wires from dimmer to LED driver should be no more than 50 meters.
  2. Switch off the power, then switch on power, repeat again. Immediately short press match key 3 times, the light on/off time will change between 3s and 0.5s.
  3. If total power of the 0/1-10V dimming driver is less than 600W, we can use AC OUT port to cut off power input of the driver.
  4. When use AC OUT port, an additional AC relay or contactor is needed when total input current of the load is higher than 3A or inrush current is greater than 30A.

## Push-Dim Function

- **Short press:** Turn on or off light.
- **Long press (1-6s):** Press and hold to step-less dimming, With every other long press, the light level goes to the opposite direction.

## Tuya APP network connection and operation

Press and hold Match/Set key for 2s, or push twice Match/Set key fastly, Clear previous network connection, enter Smart config mode, the blue LED indicator fast flash.

Press and hold Match/Set key for 5s: Clear previous network connection, enter AP config mode, the blue LED indicator fast slow. If smart config failed, please try AP config.

If Tuya APP network connection succeed, the blue LED indicator will stop flash, and in Tuya APP, you can find DIM or CCT device.

Tuya APP interface operation:  
**DIM:** Touch brightness slide to adjust brightness.

**CCT:** Touch color wheel to adjust color temperature. Touch brightness slide to adjust brightness.

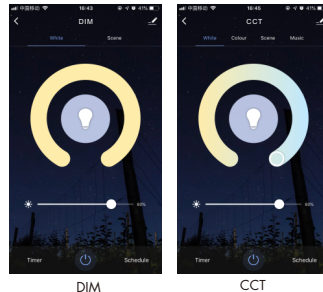

## 0-10V or 1-10V dimming setting

Select 0-10V dimmer or 1-10V dimmer according to dimmable LED driver.

### 0-10V Dimmer

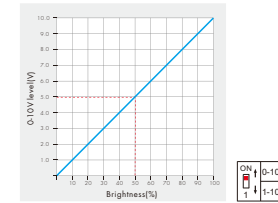

### 1-10V Dimmer

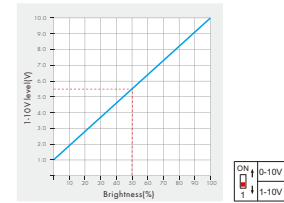

## CCT dimming setting

**ON** **CCT** Select the DIP Switch 2 ON to set as CCT light type firstly.  
**2** **DIM** [When select the DIP Switch 2 Off to set as DIM light type, Ch1 and Ch2 output is same.]

**ON** **0-10V** When power is off, select the DIP switch 1 ON, then press hold the Match key,  
**1** **1-10V** and power up the dimmer in the same time, the RUN LED indicator will flash two times, set as Ch1 for brightness adjust and Ch2 for color temperature adjust.

**ON** **0-10V** When power is off, select the DIP switch 1 OFF, then press hold the Match key,  
**1** **1-10V** and power up the dimmer in the same time, the RUN LED indicator will flash two times, set as Ch1 for warm white dimming and Ch2 for cool white dimming respectively (factory setting).

## L2(WT) match RF remote control (Optional)

End user can choose the suitable match/delete ways. Two options are offered for selection:

### Use the L2(WT)'s Match key

**Match:**  
 Short press match key of L2(WT), immediately press on/off key (single zone remote) or zone key (multiple zone remote) on the remote.

**Delete:**  
 Press and hold match key of L1(WT) for 10s to delete all match, The light blinks 5 times means all matched remotes were deleted.

### Use Power Restart

**Match:**  
 Switch off the power of L2(WT), then switch on power, repeat again. Immediately short press on/off key (single zone remote) or zone key (multiple zone remote) 3 times on the remote. The light blinks 3 times means match is successful.

**Delete:**  
 Switch off the power of L2(WT), then switch on power, repeat again. Immediately short press on/off key (single zone remote) or zone key (multiple zone remote) 5 times on the remote. The light blinks 5 times means all matched remotes were deleted.

## L2(WT) work as WiFi-RF converter to match other RF dimming LED controller or driver

End user can choose the suitable match/delete ways. Two options are offered for selection:

### Use the controller's Match key

**Match:**  
 Short press match key of the controller, immediately press on/off key on the Tuya APP. The LED indicator fast flash a few times means match is successful.

**Delete:**  
 Press and hold match key of the controller for 5s, The LED indicator fast flash a few times means match was deleted.

### Use Power Restart

**Match:**  
 Switch off the power of the controller, then switch on power, repeat again. Immediately short press on/off key 3 times on the Tuya APP. The light blinks 3 times means match is successful.

**Delete:**  
 Switch off the power of the controller, then switch on power, repeat again. Immediately short press on/off key 5 times on the Tuya APP. The light blinks 5 times means match was deleted.