

INSTRUCTION

Product Name: Motion Sensor

Model No.: MSA001S 1

Issue Date: 2021-02-21

Attention

1. The product shall be installed by a professional electrician. Please disconnect the power before installation, wiring or changing the setting of by DIP switch
2. Please read the relevant contents of this manual carefully before using the product.
3. This product is only suitable for indoor environment.
4. Ensure that the product is installed in a relatively dry and ventilated environment.
5. Before the product is powered on, please confirm that the input voltage range meets the requirements of the manual.
6. Keep out of reach of children.

1. Features

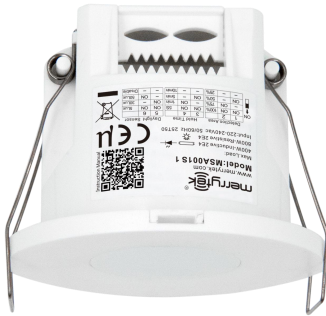

- 1) Low impedance sensor antenna patent helps anti-interference of kinds wireless signal like 5G, Wi-Fi, Bluetooth, etc.
- 2) Parameters can be set by DIP switch.
- 3) Compact size for Independent flush mounting.
- 4) Switching power supply design, complys with ERP directive.

2. Parameters

Input	Operating Voltage Range	198-264V AC 50Hz/60Hz
	Rated Voltage	220-240V AC 50Hz/60Hz
	Stand-by Power	≤0.5W
	Surge Test	L-N: 1kV
Output	Working Mode	ON/OFF function
	Type of Load	Inductive or Resistive Load
	Load Capacity	800W (Resistive), 400w(Inductive)
	Max. Surge Capacity	15A relay 30A (50% I _{peak} , twidth = 500uS@230Vac full load, cold start);
Sensor Parameters	Operating Frequency	5.8 GHz ±75 MHz, ISM Band.
	Transmitting Power	0.5mW Max.
	Hold Time	5S/1Min/5Min/10Min
	Detection Area	100%/75%/50%/25%
	Daylight Sensor	5lux/30lux/50lux/Disable (diffuse state)
	Detecting Area (radius)	≥3m
	Mounting Height	2.5-4m
Operating Environment	Operating Temperature	-25°C...+50°C
	Storage Temperature	Temperature: -40°C...+80°C; Humidity: 10%-95% (non-condensing)
Certificate Standards	Safety Standards	EN61058-1
	EMC Standards	EN300440 EN301489-1 EN55015 EN61547 EN62479
	Environmental Requirement	Compliant to RoHS
	Certificate	Compliant to CE, RED
Others	Wiring	screw type terminals, wire diameter: 0.75-1.5mm ²
	IP Rating	IP20
	Protection Class	Class II

Installation	Flush-mounted
Cut size	Φ55mm-Φ60mm
Package	White box+ White box tags+ Clapboard+ Carton(K=A)
Lifetime	5 years warranty @Ta 230V full load

Note:

The detection range of the sensor is related to the moving speed and size of moving object, mounting height, installation height and angle, installation site, reflectors around the sensor etc. The data in the document is typical value and tested by a 165cm person in an open indoor area.

The detection range at wall mounting will be longer at ceiling mounting. Please reduce detection sensitivity at wall mounting or contact us to confirm the sensor data settings.

3. Function

On/OFF Function

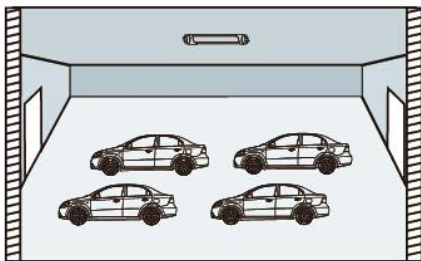

1 With sufficient ambient light, the light will not be switched on even if with motion signal.

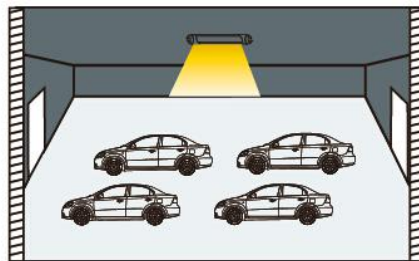

2 With insufficient ambient light, the sensor switches on the light when motion is detected.



3 After elapse of hold time, the sensor switches off the light when no motion is detected.

4. Dimension (unit: mm)

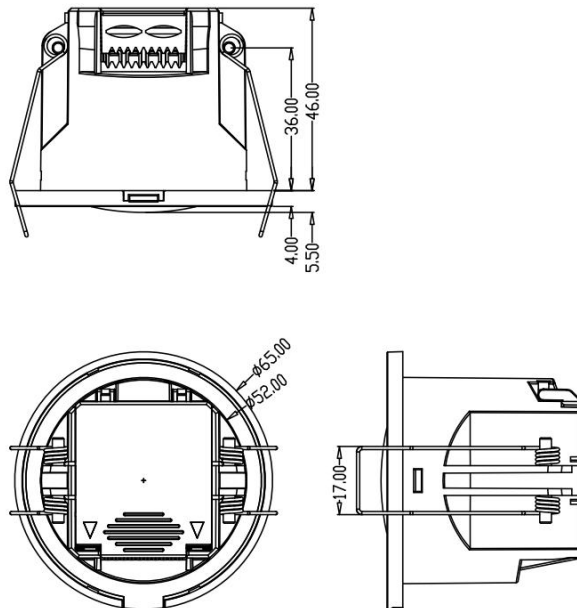

5. Wiring

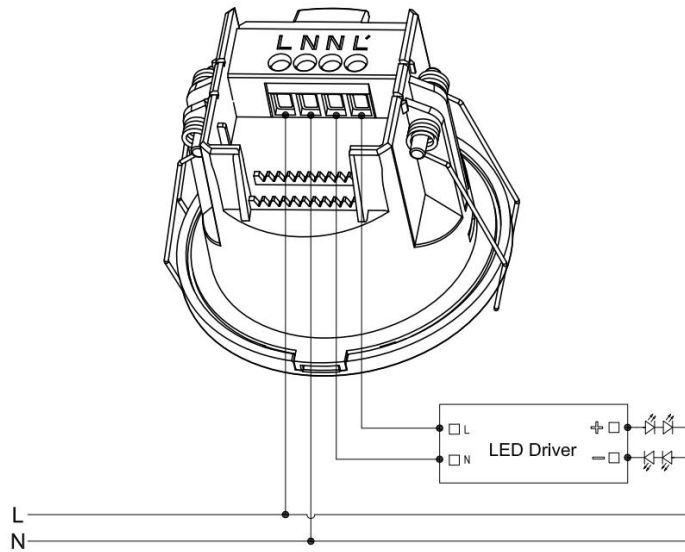

Note: When the sensor is connected with multiple loads, please refer to the surge value, the total load and the detection area, no more than 2/3 of the rated load power is recommended.

6. Structure

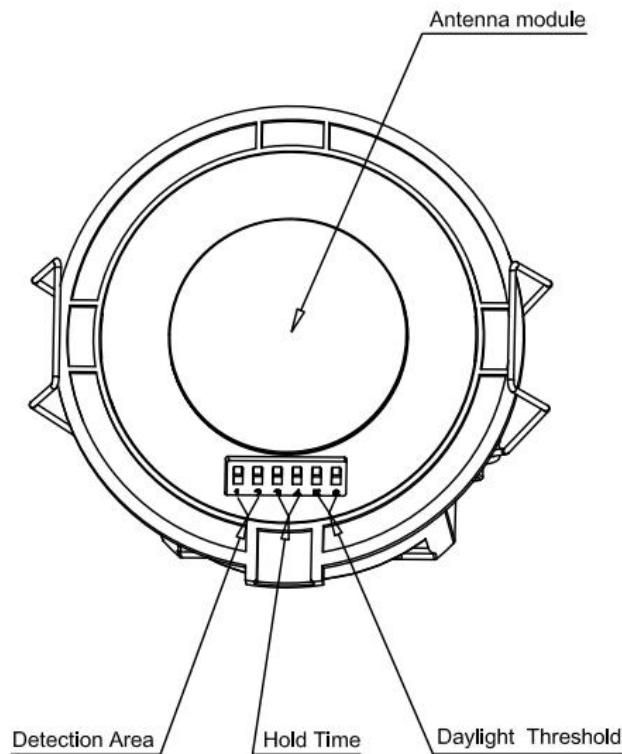

Note: Disconnect the power before parameter setting, no live operation!

Shenzhen Merrytek Technology Co.,Ltd

Add: No.17th Building, Dianda Guyuan Industrial Park, Mashantou, Matian, Guangming District, Shenzhen, China, 518106

Tel: +86 (0)755-2305 7253

Fax: +86 (0)755-2786 3012

Website: www.merrytek.com

All technical information is subject to the physical performance, Merrick reserves the right to final interpretation

7. Installation Instruction

1) Flush mounting

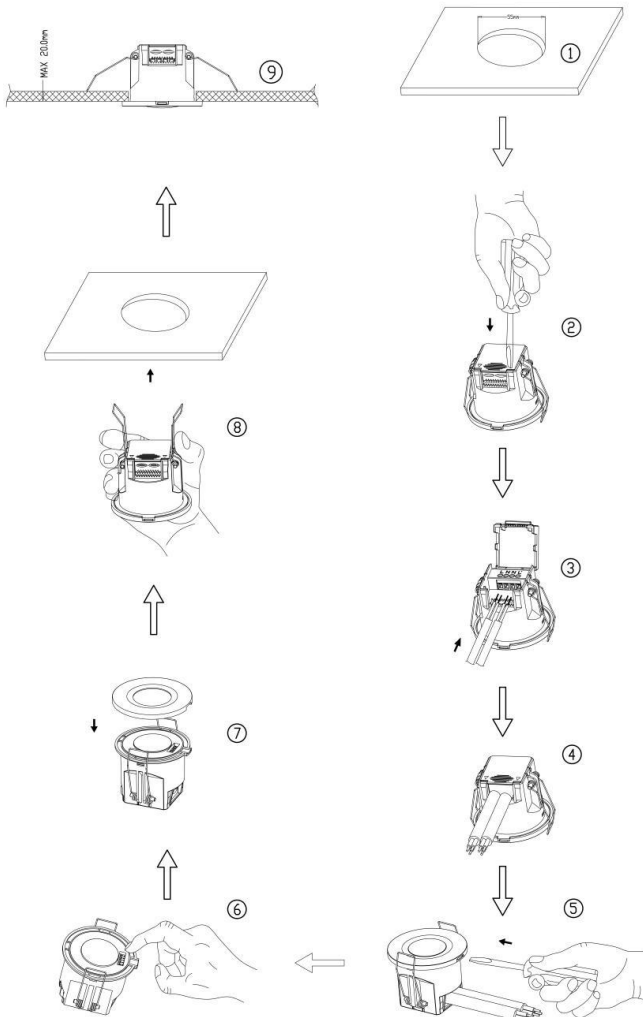

1. Ceiling cut size $\Phi 55\text{mm}$.
2. Use a flat-blade screwdriver to remove the crimping cover.
3. Connect the wires to the wiring terminals.
4. Install the crimping cover and crimp the wire.
5. Use a flat-blade screwdriver to remove the surface cover.
6. Adjust the DIP to set the parameters.
7. Cover the surface cover back to make sure that it's fastened to the main body.
8. Bending the spring clip backwards to push into the pre-cut hole in the ceiling.
9. Ensure it's stable and reliable after installation.

2) Surface mounting

Plastic case pictures:

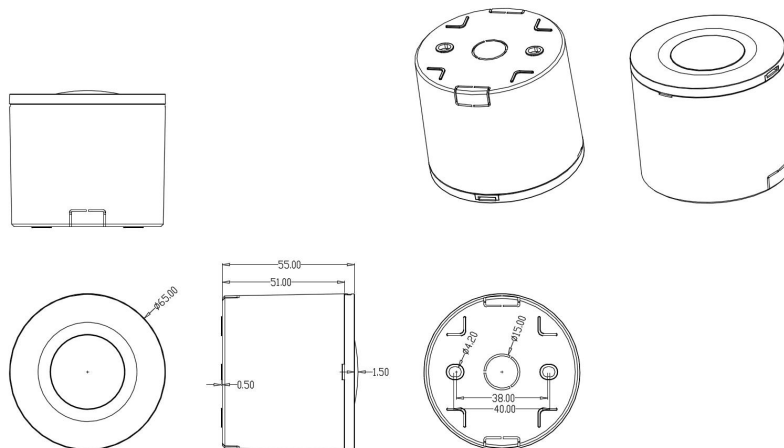

Shenzhen Merrytek Technology Co.,Ltd

Add: No.17th Building, Dianda Guyuan Industrial Park, Mashantou, Matian, Guangming District, Shenzhen, China, 518106

Tel: +86 (0)755-2305 7253

Fax: +86 (0)755-2786 3012

Website: www.merrytek.com

All technical information is subject to the physical performance, Merrick reserves the right to final interpretation

Installation step :

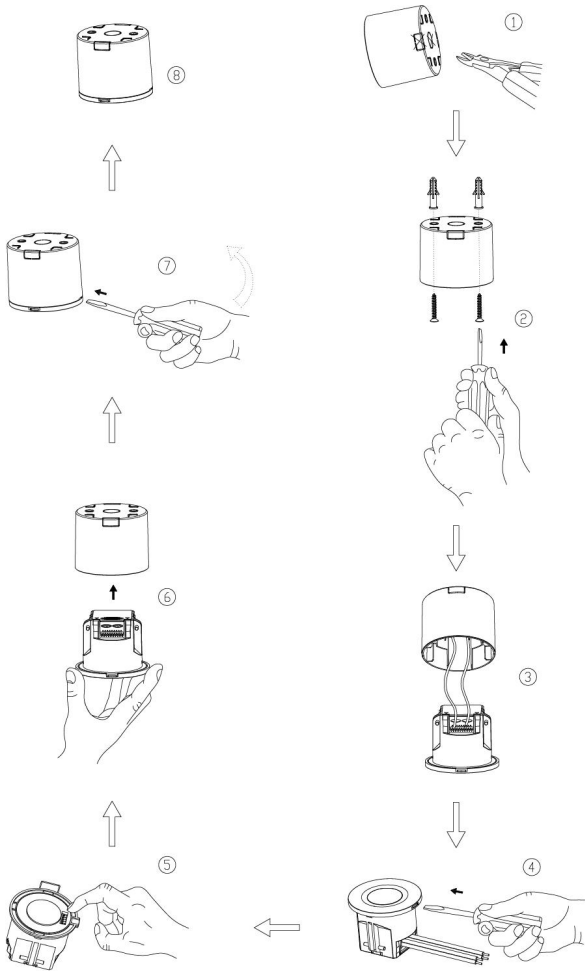

1. Cut off the reserved thin wall for the thread.
2. Fix the product on the target mounting surface by a matching screw.
3. Connect the input wire to the wiring terminal, and close the cover tightly.
4. Remove the top cover with a flat-blade screwdriver.
5. Adjust the dial code and the parameters, and then cover the top cover.
6. Push the product into the ceiling seat, the buckle will fasten the product to prevent it from falling off.
7. To separate the product from the ceiling seat, insert a flat-blade screwdriver to the disassembly gap, lift the screwdriver, and pry down with the tip, the product will pop out of the ceiling seat.
8. Ensure stable and reliable after installation.

8. Radiation Pattern

Ceiling mounting

Ceiling mounted height: 3m
Sensitivity: 100%/75%/50%/25%

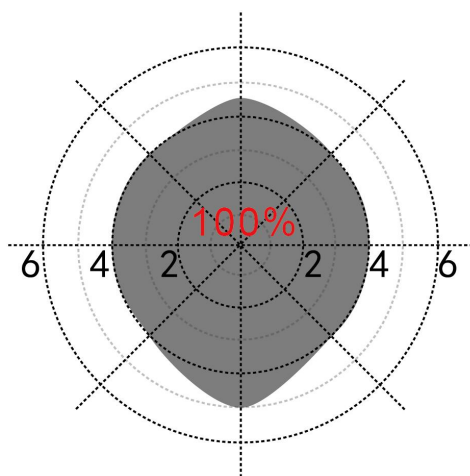

Normal moving (Speed: 1m/s)

Ceiling mounted height: 3m
Sensitivity: 100%/75%/50%/25%

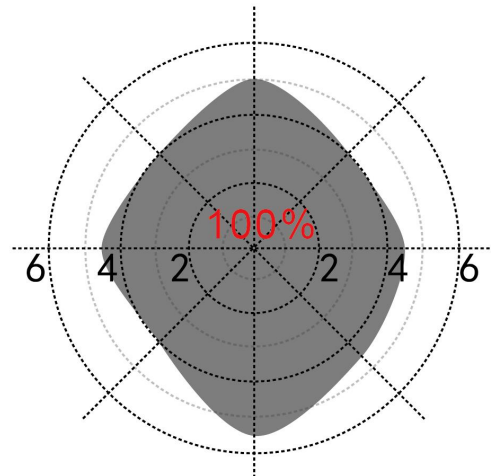

Slow moving (Speed: 0.3m/s)

Shenzhen Merrytek Technology Co.,Ltd

Add: No.17th Building, Dianda Guyuan Industrial Park, Mashantou, Matian, Guangming District, Shenzhen, China, 518106

Tel: +86 (0)755-2305 7253

Fax: +86 (0)755-2786 3012

Website: www.merrytek.com

All technical information is subject to the physical performance, Merrick reserves the right to final interpretation

9. DIP Switch Setting

Detection Area

	1	2
100%	ON	ON
75%	-	ON
50%	ON	-
25%	-	-

Hold Time

	3	4	
I	ON	ON	5S
II	-	ON	1min
III	ON	-	5min
IV	-	-	10min

Daylight Sensor

	5	6	
I	ON	ON	5Lux
II	ON	-	30Lux
III	-	ON	50Lux
IV	-	-	Disable

Note: when set to Disable, the sensor will turn on the light as long as the movement of the object is detected, regardless of whether the light is sufficient.

10. Initialization

After first power on, the light turns on and closes after 10 seconds. During the initialization, sensor is not able to detect moving objects signal.

11. Factory Settings

Detection Area: 100%

Hold Time: 5s

Daylight Sensor: Disable

12. Application Notice

1) The sensor should be installed by a professional electrician. Please disconnect the power before installing, wiring or changing the setting of the DIP switch.

2) Sensor's microwave can penetrate wall of building. It may cause misreport when microwave penetrates wall to detect the moving objects outside fortified area. To avoid triggering by mistake, choose suitable place when installing, keep away from glass, plasterboard, wooden wall and other things that microwave can easily penetrate and choose appropriate sensing parameters according to space, for examples:

A. When product is used in the room whose length and width is about 2m or less, detecting area should be set to 25% (application scenario: washroom, sitting room)

B. When product is used in the room whose length and width is about 3m, detecting area should be set to 50% (application scenario: washroom, hallway, sitting room)

C. When product is used in the room whose length and width is about 4m, detecting area should be set to 75% (application scenario: small office, meeting room, library)

D. When product is used in the room whose length and width is about 5m or more, detecting area should be set to 100% (application scenario: large office, meeting room, library)

Note: The setting detecting area depends on the actual environment (detecting area parameters above application scenario are for reference only).