

# WiFi & RF Constant Current LED CCT Driver

Model No.: PT-12A-2(WT)

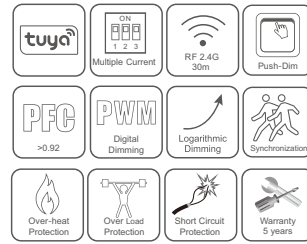

## Features

- Dimming interface: RF Wireless, AC Push-Dim
- Tuya APP cloud control, support on/off, color temperature and brightness adjust, delay turn on/off light, timer run, scene edit and music play function
- Voice control, support amazon ECHO and TmallGenie smart speaker
- Match with RF 2.4G color temperature remote control, one RF LED driver accepts up to 10 remote controls
- Universal AC input / Full range
- Flicker-free
- 2 channel constant current output, configurable current via DIP switch
- Built-in active PFC function: 0.92 Typ
- Fade in and out effect selectable
- 3 levels color temperature (WWW, NW and CW) selectable by continuous power off and on operation
- Overheat / Over-load / Short circuit protection, recover automatically
- Full protective plastic case
- Suitable for indoor LED lighting application
- 5 Year, 50,000hr warranty

## Mechanical Structures and Installations

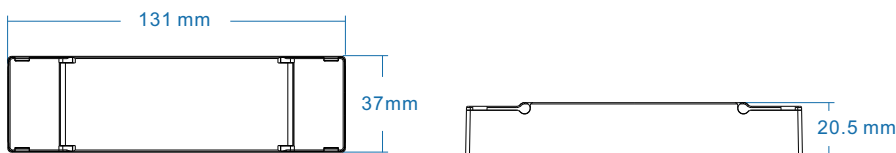
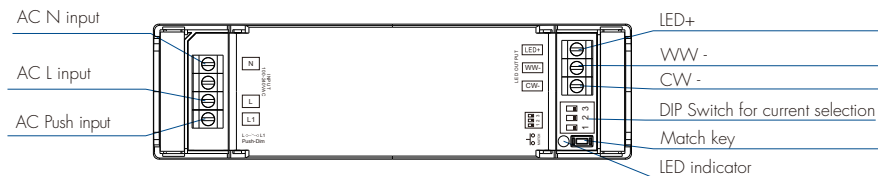

## Technical Parameters

Output	Output Voltage	10~45VDC
	Output Current	2x (150~500) mA
	Output Power	Max. 12W
	Max Output Voltage	48VDC
	Dimming Range	0~100%
	PWM Frequency	8000Hz
	Current Accuracy	±5%
Ripple&Noise	< 120mV	
Input	Input Voltage Range	100~240VAC
	Frequency Range	50/60Hz
	Efficiency	>77%
	Alternating Current	0.166A Max.
	Anti Surge	L-N: 1.2KV
	Startup time	1S/230VAC
	Power Factor	>0.97/110VAC, >0.92/230VAC
	THD	<8%
	Inrush Current	Cold start 7.4A at 230VAC
	Leakage Current	< 0.5mA/230VAC
	No Load Power	<2W
	Protection	Over Load Power
Short Circuit		Shut down automatically if short circuit occurs, auto recovers.
Over Temperature		Intelligently adjust or turn off the output current if the PCB temp > 100°C, auto recovers.
Environment	Working Temperature	-30°C~50°C
	Tcase Max	80°C
	Working Humidity	20%~90%RH, non-condensing
	Storage Temp/Humidity	-40°C~80°C, 10%~95%RH
	Temperature Coefficient	±0.03%/°C (0-50%)
	Vibration Resistance	10-500Hz, 2G, 6min/cycle, X,Y,Z axes/2min
IP Rating	IP20	
Safety&EMC	Security Specifications	IEC/EN61347-1, IEC/EN61347-2-13
	Withstand Voltage	I/PO/P: 3750VAC
	Insulation Resistance	I/PO/P: 100MΩ/500VDC/25°C/70%RH
	EMC Emission	EN55015, EN61000-3-2 Class C, IEC61000-3-3
	EMC Immunity	EN61000-4-2, 3.4.5.6.8.11, EN61547
	Certifications	CE, EMC

## LED Current Selection:

ON ↑	1 2 3	<input type="checkbox"/>	<input type="checkbox"/>	<input type="checkbox"/>	<input type="checkbox"/>	<input type="checkbox"/>	<input type="checkbox"/>	<input type="checkbox"/>	<input type="checkbox"/>
	Uout	10-42V	10-42V	10-42V	10-40V	10-34V	10-30V	10-27V	10-24V
OFF ↓	Iout	150mA	200mA	250mA	300mA	350mA	400mA	450mA	500mA

## Applications

- Suitable for downlight, spotlight and decorative applications.
- Office / Commercial / Domestic Lighting, Hotels, Classrooms, Warehouse, Health care, Retail and Display.
- Use for retrofit upgrades & new luminaire designs.

## System wiring

### 1. WiFi & RF Connection

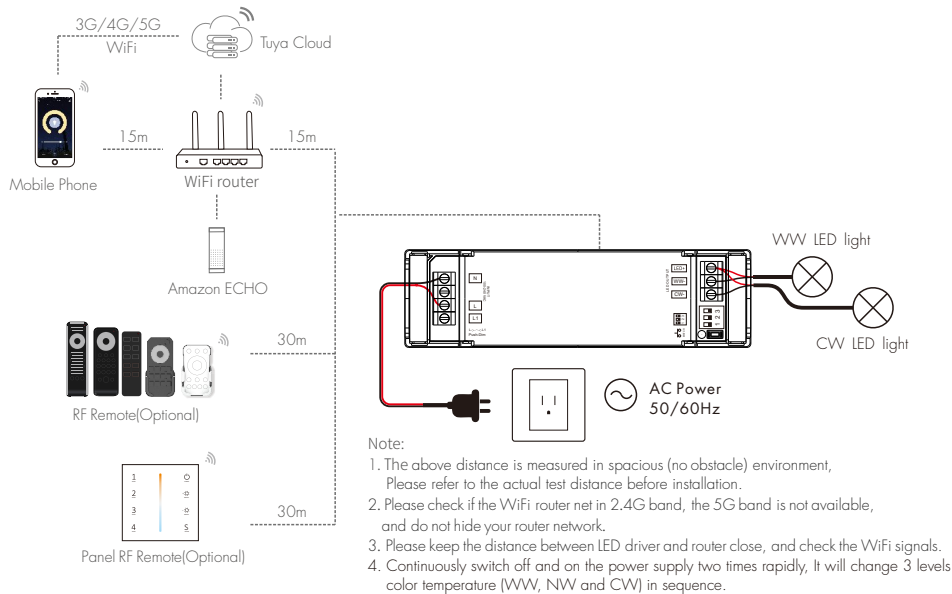

### Tuya APP network connection

Press and hold Match key for 2s, or push twice Match key fastly:  
Clear previous network connection, enter Smart config mode, the LED indicator flash fastly, the output LED will flash 10 times.

Press and hold Match key for 5s:  
Clear previous network connection, enter AP config mode, the LED indicator flash slowly.  
If smart config failed, please try AP config.

Repeat power on and off for 5 consecutive times, also clear previous network connection, enter Smart config mode, the output LED will flash 10 times.

If Tuya APP network connection succeed, the LED indicator will stop flash, and in Tuya APP, you can find the CCT device.

### Match Remote Control (two match ways)

End user can choose the suitable match/delete ways. Two options are offered for selection:

#### Use Match key

Match:  
Short press match key, immediately press on/off key (single zone remote) or zone key (multiple zone remote) of the remote.

Delete:  
Press and hold match key for 10s to delete all match, The light blinks 5 times means all matched remotes were deleted.

#### Use Power Restart

Match:  
Switch off the power, then switch on power, repeat again. Immediately short press on/off key (single zone remote) or zone key (multiple zone remote) 3 times on the remote. The light blinks 3 times means match is successful.

Delete:  
Switch off the power, then switch on power, repeat again. Immediately short press on/off key (single zone remote) or zone key (multiple zone remote) 5 times on the remote. The light blinks 5 times means all matched remotes were deleted.

## PT-12A-2(WT) WiFi & RF Constant Current LED CCT Driver

### 2. AC Push-Dim connection

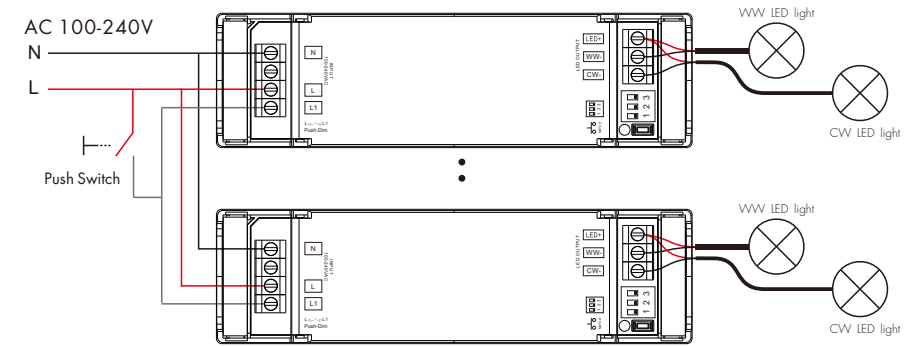

The provided AC Push-Dim interface allows for a simple dimming method using commercially available non-latching (momentary) wall switches.

- **Short press:**  
Turn on or off light.
- **Long press (1-6s):**  
Press and hold to step-less dimming, With every other long press, the light level goes to the opposite direction.
- **Dimming memory:**  
Light returns to the previous dimming level when switched off and on again, even at power failure.
- **Synchronization:**  
If more than one LED driver are connected to the same push switch, do a long press for more than 10s, then the system is synchronized and all lights in the group dim to 100%. This means there is no need for any additional synchrony wire in larger installations. We recommend the number of LED drivers connected to a push switch does not exceed 25 pieces, The maximum length of the wires from push to LED driver should be no more than 50 meters.

### Fade in and Fade out Setting

Switch off the power, then switch on power, repeat again.  
Immediately short press match key 3 times, the light on/off time will change between 3s and 0.5s.

### Dimming Curve

