

ZigBee & RF AC Triac Dimmer

Model No.: S1-B(WZ)

Tuya APP cloud control/Philips HUE control/Voice control/RF dimming/Push Dim/Leading edge or trailing edge

Features

- ZigBee + RF + Push AC phase-cut dimmer, 1 channel output.
- To dim and switch single color dimmable LED lamps, traditional incandescent and halogen lights.
- Tuya APP cloud control, support on/off, brightness adjust, delay turn on/off light, timer run, scene and music play function.
- Philips HUE APP control by connect with Philips HUE bridge.
- Voice control, support amazon ECHO and TmallGenie smart speaker.
- 256 levels 0-100% dimming smoothly without any flash.
- Leading edge dimming or trailing edge dimming set by dip switch.
- Min brightness can be set by key.
- Light on/off fade time 3s selectable.
- Compatibility with RF 2.4G single zone or multiple zone dimming remote control.
- Each S1-B(WZ) controller can also work as ZigBee-RF converter, then use Tuya APP to control one or more RF dimming LED controller or driver synchronously.
- Connect with external push switch to achieve on/off and 0-100% dimming function.
- Easy to be placed in standard wall junction box behind a push switch.
- Over-heat / Over-load protection, recover automatically.



CE RoHS EMC LVD

Technical Parameters

Input and Output	
Input voltage	AC100-240V
Output voltage	AC100-240V
Output current	Max 1.5A
Output power	150-360W

Environment	
Operation temperature	Ta: -30°C ~ +55°C
Case temperature (Max.)	Tc: +85°C
IP rating	IP20

Warranty	
Warranty	5 years

Safety and EMC	
EMC standard (EMC)	ETSI EN 301 489-1 V2.2.3 ETSI EN 301 489-17 V3.2.4
Safety standard(LVD)	EN 62368-1:2020+A11:2020
Radio Equipment(RED)	ETSI EN 300 328 V2.2.2
Certification	CE,EMC,LVD,RED

Dimming data	
Input signal	Tuya APP + RF + Push Dim
RF Control distance	30m(Barrier-free space)
Dimming level	256 levels
Dimming range	0-100%

Weight	Net weight	Gross weight
Weight unit(g)	0.048kg	0.061kg

Mechanical Structures and Installations

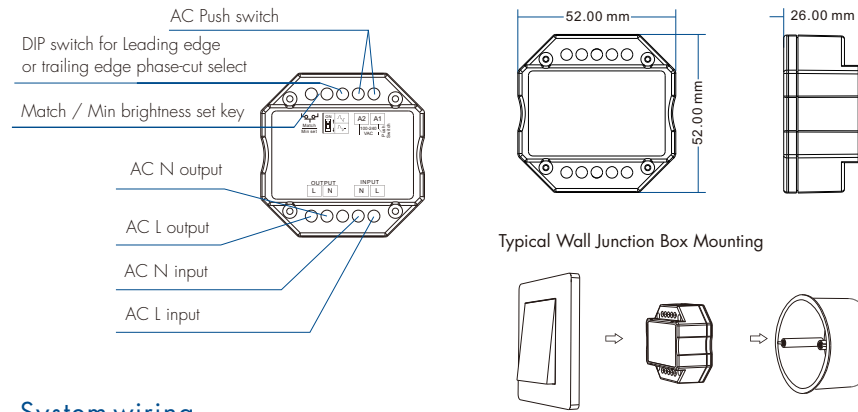

System wiring

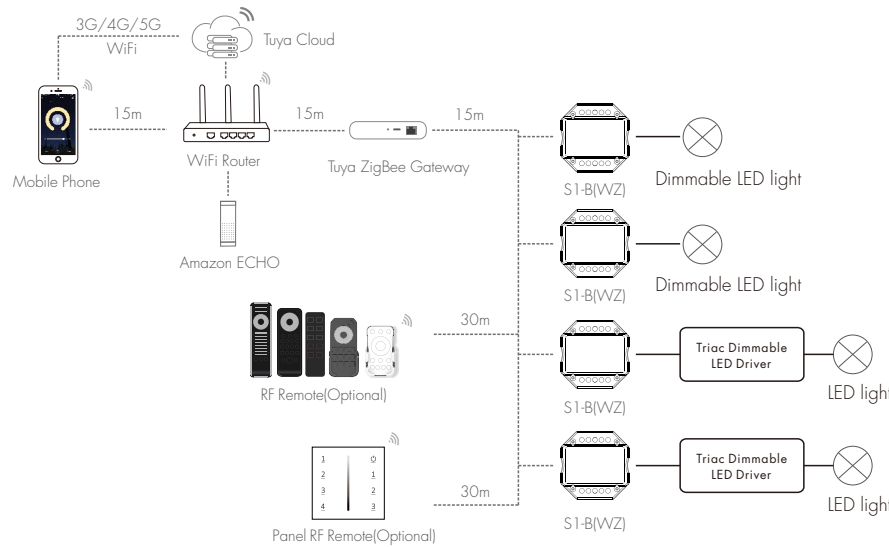

— Wired connection
 Wireless connection

Note:

1. The above distance is measured in spacious (no obstacle) environment, Please refer to the actual test distance before installation.
2. Users must use the Tuya ZigBee gateway to realize remote control and voice control.

Wiring diagram

Caution: Please carefully ensure all wire connections and polarities are correct and secure before applying power, otherwise this controller will be damaged.

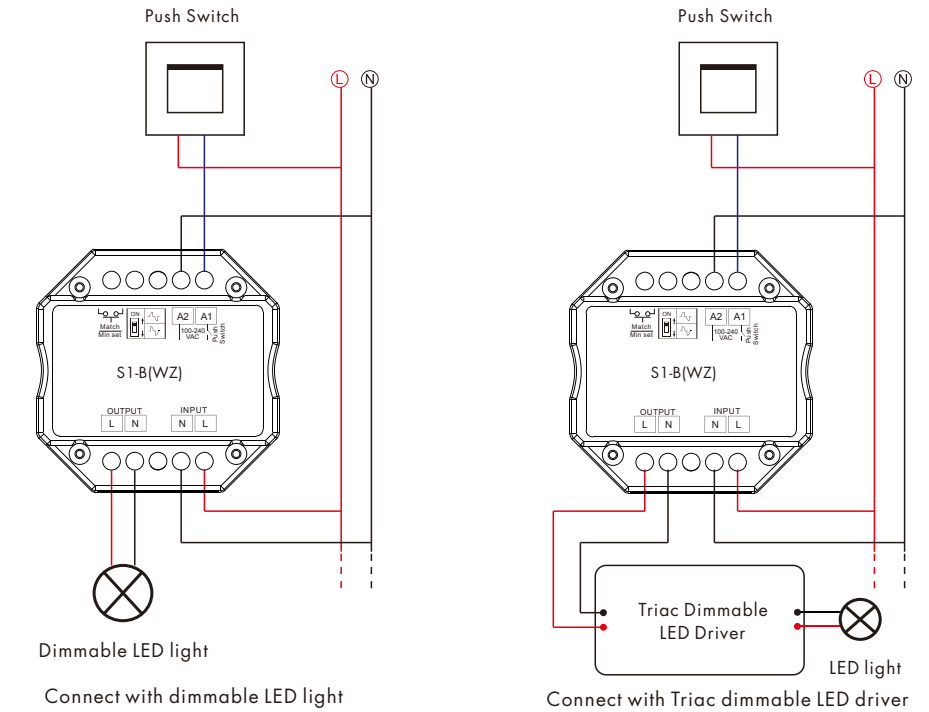

Note: When calculating the maximum number of load lamps or drivers, the input power or input current parameters of a single lamp or driver must be used, the output power parameters can not be used. In addition, the maximum surge current of the dimmer is 65A, the sum of surge current of multiple dimmable LED drivers should not exceed 2 times. otherwise, the product will be overloaded and damaged.

Compatible Load Types

Load Type	Maximum Load	Remarks
Dimmable LED lamps	200W @ 220V 100W @ 110V	Due to variety of LED lamp designs, maximum number of LED lamps is further dependent on power factor result when connected to dimmer.
Triac Dimmable LED drivers	200W @ 220V 100W @ 110V	Maximum permitted number of drivers is 200W divided by driver nameplate power rating, and make sure the surge current is no more than 2 times 65A.
Incandescent lighting, HV Halogen lamps	400W @ 220V 200W @ 110V	

Leading edge or trailing edge dimming setting

Select leading edge(forward-phase) dimmer or trailing edge(reverse-phase) dimmer according to dimmable LED light or driver.

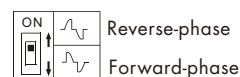

Forward-phase control dimmer(TRIAC)

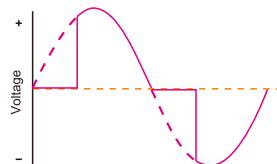

Reverse-phase control dimmer

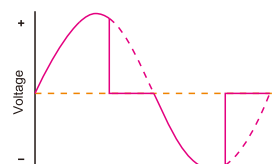

Caution: before power on, you must confirm the selection of dip switch.

Min brightness setting

Long press Min set key for 10s, the light blink 2 times, ready for min brightness set, then short press Min set key 1-6 times, to get 6 min brightness: 5%, 10%, 15%, 20%, 25% or 30%, the light will output the current min brightness immediately, Wait 8s, quit min brightness set automatically, the light will return output 100% brightness.

Tuya APP network connection and operation

Press and hold Match/Set key for 2s, reset ZigBee network.

Press and hold Match/Set key for 5s, or push twice Match/Set key fastly, Clear previous network connection, enter config mode. the blue LED indicator fast flash.

Repeat power on and off for 5 consecutive times, also clear previous network connection, enter config mode.

If Tuya APP network connection succeed, the blue LED indicator will stop flash, and in Tuya APP, you can find ZB-DIM device.

Tuya APP interface operation:
Touch brightness slide to adjust brightness.

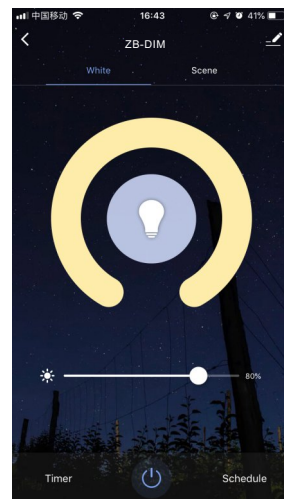

S1-B(WZ) match RF remote control (Optional)

End user can choose the suitable match/delete ways. Two options are offered for selection:

Use the S1-B(WZ)'s Match key

Match:
Short press match key of S1-B(WZ), immediately press on/off key (single zone remote) or zone key (multiple zone remote) on the remote.

Delete:
Press and hold match key of S1-B(WZ) for 15s to delete all match, The light blinks 5 times means all matched remotes were deleted.

Use Power Restart

Match:
Switch off the power of S1-B(WZ), then switch on power, repeat again, Immediately short press on/off key (single zone remote) or zone key (multiple zone remote) 3 times on the remote. The light blinks 3 times means match is successful.

Delete:
Switch off the power of S1-B(WZ), then switch on power, repeat again, Immediately short press on/off key (single zone remote) or zone key (multiple zone remote) 5 times on the remote. The light blinks 5 times means all matched remotes were deleted.

S1-B(WZ) work as ZigBee-RF converter to match other RF dimming LED controller or driver

End user can choose the suitable match/delete ways. Two options are offered for selection:

Use the controller's Match key

Match:
Short press match key of the controller, immediately press on/off key on the Tuya APP. The LED indicator fast flash a few times means match is successful.

Delete:
Press and hold match key of the controller for 5s, The LED indicator fast flash a few times means match was deleted.

Use Power Restart

Match:
Switch off the power of the controller, then switch on power, repeat again, Immediately short press on/off key 3 times on the Tuya APP. The light blinks 3 times means match is successful.

Delete:
Switch off the power of the controller, then switch on power, repeat again, Immediately short press on/off key 5 times on the Tuya APP. The light blinks 5 times means match was deleted.

AC Push Dim Function (Optional)

- **Short press:**
Turn on or off light.
- **Long press (1-6s):**
Press and hold to step-less dimming, With every other long press, the light level goes to the opposite direction.
- **Dimming memory:**
Light returns to the previous dimming level when switched off and on again, even at power failure.

Light on/off fade time

Switch off the power, then switch on power, repeat again. Immediately short press match key 3 times, the light on/off time will change between 3s and 0.5s.